

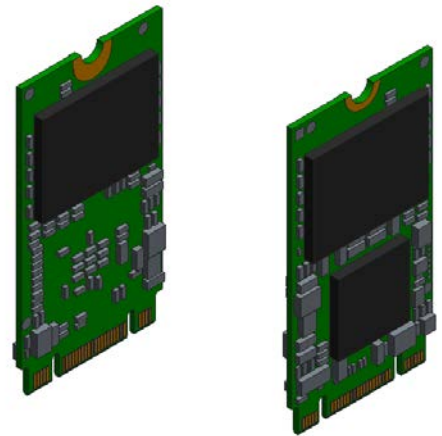

SMART Embedded Products

SMART MODULAR M.2 SATA XL+ SLC

SH9M2S46DxxxGJSxxx



January 2015, Rev A



www.smartm.com

REVISION HISTORY

Date	Revision	Section(s)	Description
January 2015	A	All	Initial release.



ESD Caution – Handling

Static electricity may be discharged through this disk subsystem. In extreme cases, this may temporarily interrupt the operation or damage components. To prevent this, make sure you are working in an ESD-safe environment. For example, before handling the disk subsystem, touch a grounded device, such as a computer case, prior to handling.

SMART Modular Technologies

39870 Eureka Dr.
Newark, CA 94560
(510) 623-1231 voice
(510) 623-1434 fax
info@smartm.com
An ISO 9001 certified company.

©2015 SMART Modular Technologies. All rights reserved.

Corporate Headquarters: 39870 Eureka Dr, Newark, CA 94560, USA • Tel:(510) 623-1231 • Fax:(510) 623-1434 • E-mail: info@smartm.com
Flash Design Center: 2 Highwood Dr, Suite 101, Tewksbury, MA 01876 USA • Tel:(978) 221-3500 • Fax:(978) 303-8757
Asia: Plot 18, Lrg Jelawat 4, Kawasan Perindustrian Seberang Jaya 13700, Prai, Penang, Malaysia • Tel: +604-3992909 • Fax: +604-3992903

TABLE OF CONTENTS

1	GENERAL DESCRIPTION	6
1.1	Overview	6
1.2	Features.....	7
1.3	Unique Features.....	8
2	OPERATIONAL CHARACTERISTICS	9
2.1	Performance	9
2.2	Power.....	10
2.3	Reliability.....	10
2.4	Endurance.....	11
2.5	Mean Time Between Failures (MTBF).....	11
2.6	Environmental Conditions	12
2.7	Physical Characteristics	12
3	PRODUCT DESCRIPTION.....	13
3.1	Functional Block Diagram	13
4	REGULATORY COMPLIANCE	14
5	MECHANICAL SPECIFICATION	15
6	ELECTRICAL SPECIFICATION.....	16
6.1	Electrical Interface.....	16
6.1.1	M.2 Dual Key B-M SATA Interface	16
6.1.2	Pin Out Descriptions.....	17
6.2	Absolute Maximum Ratings.....	17
6.3	Recommended Operating Conditions.....	17
7	ATA COMMANDS.....	18
7.1	Supported ATA Commands	18
7.2	Supported S.M.A.R.T. Operations.....	20
7.2.1	Supported S.M.A.R.T. Subcommands.....	20
7.2.2	Supported S.M.A.R.T. Data Structure.....	21
7.2.3	Supported S.M.A.R.T. Attributes	22
7.3	Supported DCO Subcommands	23
7.4	Supported HPA Subcommands.....	23
7.5	Identify Drive	24
8	PART NUMBERS.....	28
8.1	Part Numbering Information	28
8.2	Part Number Decoder	29

LIST OF FIGURES

Figure 1: M.2 SATA SSD Block Diagram	13
Figure 2: M.2 2242-D3-B-M Dimensions (in mm)	15
Figure 3: M.2 Dual Key B-M SATA Interface	16

LIST OF TABLES

Table 1: Performance Characteristics	9
Table 2: Power Requirements (3.3 V)	10
Table 3: Power Consumption	10
Table 4: Reliability Characteristics	10
Table 5: MTBF Values	11
Table 6: Environmental Conditions and Test Conditions	12
Table 7: Physical Characteristics	12
Table 8: Regulatory Description	14
Table 9: Pin Out Descriptions	17
Table 10: Absolute Maximum Ratings.....	17
Table 11: Recommended Operating Conditions.....	17
Table 12: Supported ATA Commands	18
Table 13: Supported S.M.A.R.T. Subcommands.....	20
Table 14: Supported S.M.A.R.T. Data Structure	21
Table 15: Supported S.M.A.R.T. Attributes	22
Table 16: Supported DCO Subcommands	23
Table 17: Supported HPA Subcommands.....	23
Table 18: Identify Device Information.....	24
Table 19: Device Identification by Capacity.....	27
Table 20: Part Numbering Information	28

1 GENERAL DESCRIPTION

1.1 Overview

The SMART Modular M.2 SATA embedded (internal) SATA module is a robust, solid state drive product. This drive specifically targets the needs of OEM markets, such as server, storage cache/accelerators, networking, and data communications applications requiring reliable internal storage with a small footprint. The embedded products are also a natural fit for mobile and embedded computing, medical, automotive, and industrial applications. The low power consumption and fast data throughput are major advantages of the SMART Modular M.2 SATA modules over traditional rotating hard disk drives (HDDs).

Utilizing an industry-standard SATA interface and connector, M.2 SATA modules are easily integrated into a host system without any special BIOS modifications or additional device drivers. These products offer sustained read performance up to 510 MB/s and sustained write performance of up to 140 MB/s. These modules are available in capacities of 8 GB to 64 GB.

SMART Modular M.2 SATA products address the need for enhanced reliability by incorporating on-board error detection and correction and static wear leveling algorithms to provide reliable operation over the product life cycle.

SMART has built its foundation by providing proven technology and quality products to the most demanding Fortune 100 OEMs. SMART engineers its products to perform at the highest degree of reliability and compatibility while backing these products with outstanding services and technology expertise.

1.2 Features

- **Form Factor:** PCI Express M.2 Specification, M.2 2242-D3-B-M
- **Interface:** Industry standard Serial ATA, SATA 3.2 compliant
- **Supported SATA modes**
 - **PIO Modes:** 0 – 4
 - **Multiword DMA Modes:** 0 – 2
 - **Ultra DMA Modes:** 0 – 6
- **SATA Interface Transfer Rate:** 6 Gb/s with support for 3 Gb/s and 1.5 Gb/s
- **NAND Technology:**
 - Single Level Cell (SLC)
- **Capacity:** 8 GB to 64 GB
- **Data Rates:**
 - **Read:**
 - Up to 510 MB/s (16 GB – 64 GB)
 - Up to 270 MB/s (8 GB)
 - **Write:**
 - Up to 140 MB/s (16 GB – 64 GB)
 - Up to 80 MB/s (8 GB)
- **Operating Temperature:**
 - **Commercial:** 0°C to 70°C
 - **Industrial:** -40°C to 85°C
- **Storage Temperature:** -40°C to 85°C
- **Input Power:**
 - **V_{CC}:** 3.3 V ± 5%

1.3 Unique Features

- Static and Dynamic Wear Leveling
- Advanced Error Detection/Correction circuitry for superior data reliability
- Self-Monitoring Analysis and Reporting Technology (S.M.A.R.T.) support
- Supports for 48-bit LBA addressing with larger max transfer size
- Improved shock and vibration performance over rotating media
- ATA and SATA Interface Power Management Support
- External LED Activity Signaling through the connector
- Native Command Queuing (NCQ) support with a maximum queue depth of 32
- Zero seek time
- Noiseless operation
- Supports TRIM command based on the ATA-8 Standard
- Supports ATA Download Microcode
- Low power management
 - DIPM/HIPM Mode
 - DEVSLP Mode
- Bad Block Management

2 OPERATIONAL CHARACTERISTICS

All listed values are typical unless otherwise stated.

2.1 Performance

Table 1: Performance Characteristics

Item	Capacity	Performance (Maximum)
128K Sequential Read Sustained	64 GB	510 MB/s
	32 GB	510 MB/s
	16 GB	510 MB/s
	8 GB	270 MB/s
128K Sequential Write Sustained	64 GB	140 MB/s
	32 GB	130 MB/s
	16 GB	130 MB/s
	8 GB	80 MB/s
4K Random Read Maximum (2)	64 GB	34K IOPS
	32 GB	41K IOPS
	16 GB	46K IOPS
	8 GB	38K IOPS
4K Random Write Maximum (2)	64 GB	27K IOPS
	32 GB	26K IOPS
	16 GB	27K IOPS
	8 GB	17K IOPS
Host Interface Transfer Rate	All	6.0 Gb/s / 3.0 Gb/s / 1.5 Gb/s (depends on host connection)
Response Time	All	< 710 ms (max) < 0.5 ms (typical)

(1) Tested on ASUS Q87 + i7 + Win7 64-bit + 16 GB RAM.

(2) Test result obtained with IOMeter 2008 running 'full random' data pattern.

2.2 Power

Table 2: Power Requirements (3.3 V)

Parameter	Value (Typical)	Value (Maximum)	Unit
V _{CC}	3.3	3.6	V
Read	540	750	mA
Write	420	730	mA
Idle	90	110	mA

Table 3: Power Consumption

Capacity	Read	Write	Partial	Slumber	Idle	DEVSLP	Unit
8 GB	1,150	960	40	25	270	4.5	mW
16 GB	1,720	1,230	45	25	280	4.8	mW
32 GB	1,720	1,390	45	25	290	4.9	mW
64 GB	1,780	1,390	45	25	290	4.9	mW

- (1) The RMS value of power consumption is achieved based on 100% conversion efficiency.
- (2) The measured power voltage is 3.3 V.
- (3) Samples were built using Toshiba 24nm Toggle SLC NAND flash and measured under ambient temperature.
- (4) Sequential R/W is measured while testing 4000 MB sequential R/W 5 times by CrystalDiskMark.
- (5) Power Consumption may differ according to flash configuration, SDR configuration, and platform.

2.3 Reliability

Table 4: Reliability Characteristics

Item	Value	
Mean Time Between Failures (MTBF)	> 2 Million hours	
Data Reliability	< 1.0E-15 uncorrectable error rate	
Data Retention (@ 25°C)	10 years > 90% life remaining	
	1 year < 10% life remaining	
Endurance ⁽¹⁾ 100% Sequential Workload	8 GB	700 TBW
	16 GB	1390 TBW
	32 GB	2740 TBW
	64 GB	5480 TBW
Endurance ⁽¹⁾ JEDEC Enterprise Class Workload	8 GB	50 TBW
	16 GB	105 TBW
	32 GB	170 TBW
	64 GB	350 TBW
Error Correction / Error Detection	Up to 68 bits for every 1 KB of user data	

(1) *Endurance is directly related to the User Specific Workload.*

2.4 Endurance

- **Static and Dynamic Wear Leveling:** This feature eliminates overstressing flash media by spreading the data writes across all flash physical address space, including logical areas that are not written by the user. The data is wear leveled across the entire drive.
- **ECC:** Utilize BCH ECC to provide correction of up to 68 random single-bit errors per 1 KB of user data.
- **Bad Block Management:** This feature tracks all manufacturing and run-time bad blocks of flash media and replaces them with new ones from the spare pool.

2.5 Mean Time Between Failures (MTBF)

MTBF can be calculated using Telcordia SR-232. issue 2 Parts count method.

Table 5: MTBF Values

Drive @ 50°C	MTBF (Hours)
All Capacities	> 2 million

2.6 Environmental Conditions

Table 6: Environmental Conditions and Test Conditions

Parameter	Value
Operating Temperature - Commercial	0°C to 70°C
Operating Temperature - Industrial	-40°C to 85°C
Storage Temperature	-40°C to 85°C
ESD	64 GB, 24.0°C, 49% (RH), ± 4 KV

2.7 Physical Characteristics

Table 7: Physical Characteristics

Parameter	Value
Length	42 mm [1.65 in]
Width	22 mm [0.87 in]
Height	3.65 mm [0.14 in]

3 PRODUCT DESCRIPTION

The SMART M.2 SATA SSD contains a 6 Gb/s SATA interface controller and a NAND flash controller with corresponding flash memory devices. This system architecture logically and efficiently translates standard SATA HDD commands into flash memory accesses. Parallel access to the flash memory allows overlapped, multi-block access to complete data transfer requests rapidly. Efficient local voltage converters provide the power for logic and memory from the standard SATA power connection using switching regulators to minimize wasted power.

3.1 Functional Block Diagram

Figure 1: M.2 SATA SSD Block Diagram

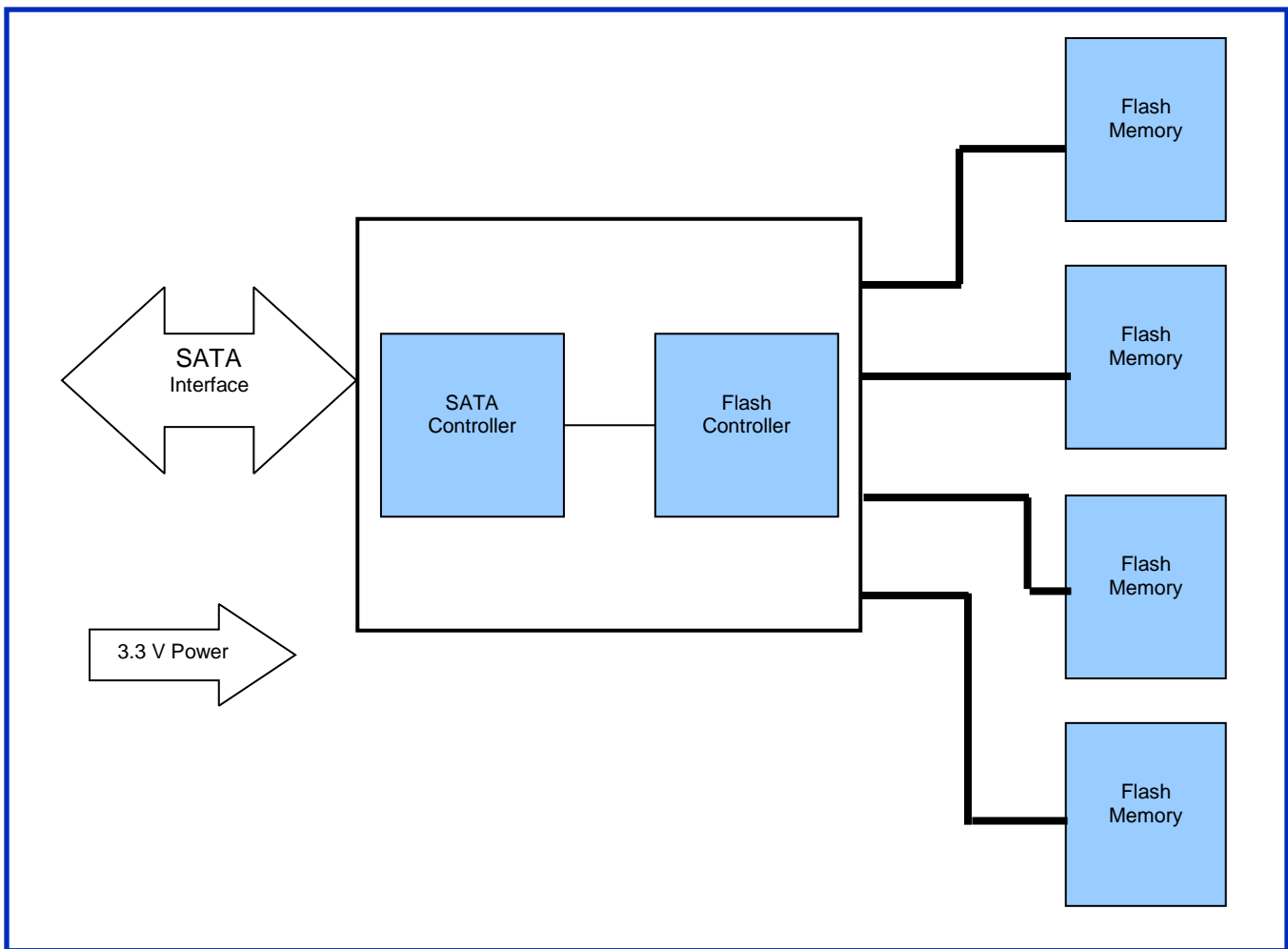

4 REGULATORY COMPLIANCE

The SMART Modular M.2 SATA SSD product complies with the regulatory requirements identified in the following table.

Table 8: Regulatory Description

Regulation	Compliance (Country/Region)
EMC	FCC Part 15, Class B (USA); IC ICES-003, Class B (Canada); EMC Directive 2004/108/EC - EN 55022, Class B and EN 55024 (EU), CISPR 22, Class B and CISPR 24 (International)
Safety	UL Listed E153169, UL 60950-1 (USA); cUL Listed E153169, CSA C22.2 No. 60950-1-07 (Canada); LV Directive 2006/95/EC - EN 60950-1, CB Certificate (EU), IEC 60950-1, CB Certificate (International)
RoHS	RoHS Directive 2011/65/EU - EN 50581 (EU)



5 MECHANICAL SPECIFICATION

Conforms to PCI Express M.2 Specification, M.2 2242-D3-B-M

Figure 2: M.2 2242-D3-B-M Dimensions (in mm)

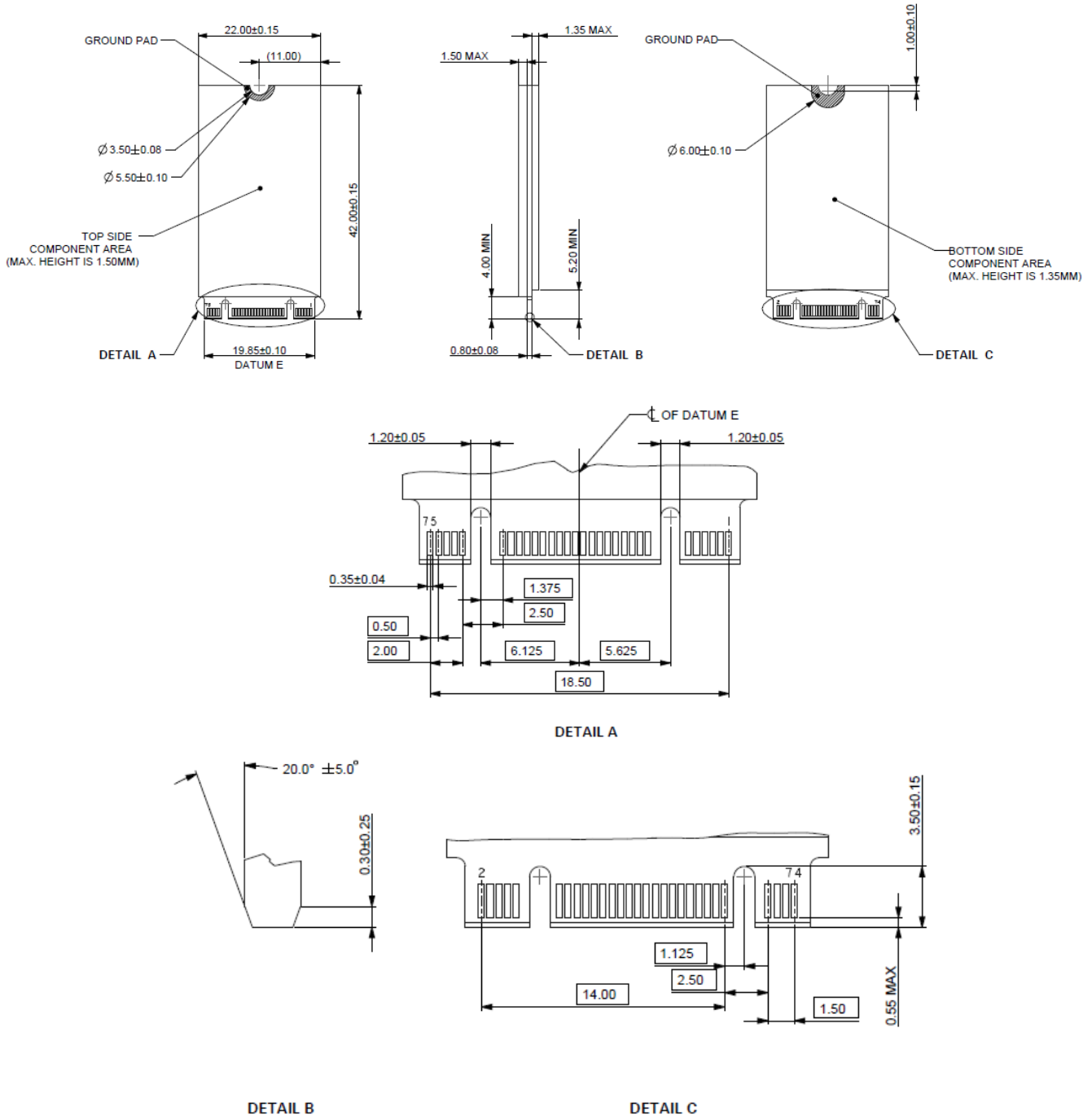

6 ELECTRICAL SPECIFICATION

6.1 Electrical Interface

The M.2 SATA drive is compliant with the SATA III, 6.0 Gb/s standard.

6.1.1 M.2 Dual Key B-M SATA Interface

Figure 3 shows the pin-outs for the M.2 SATA drive.

Figure 3: M.2 Dual Key B-M SATA Interface

Top View

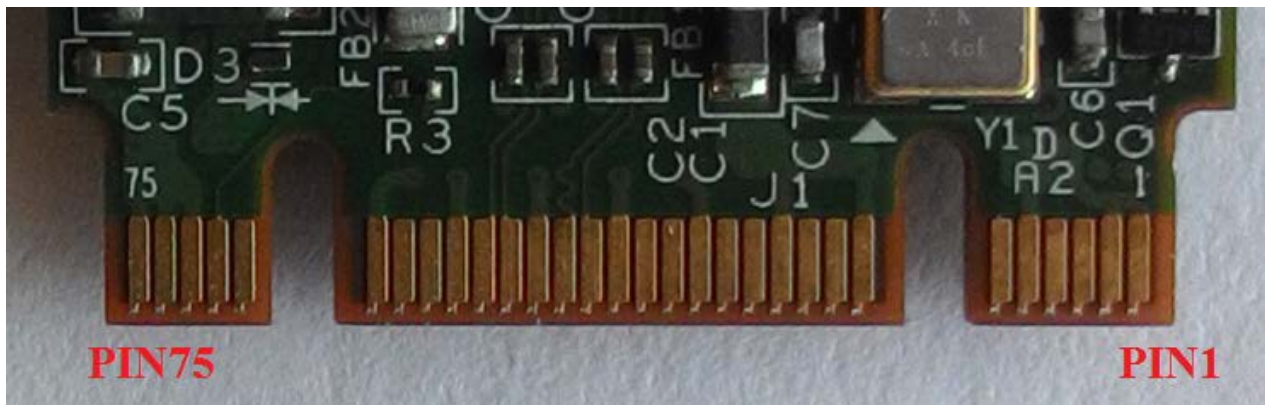

Bottom View

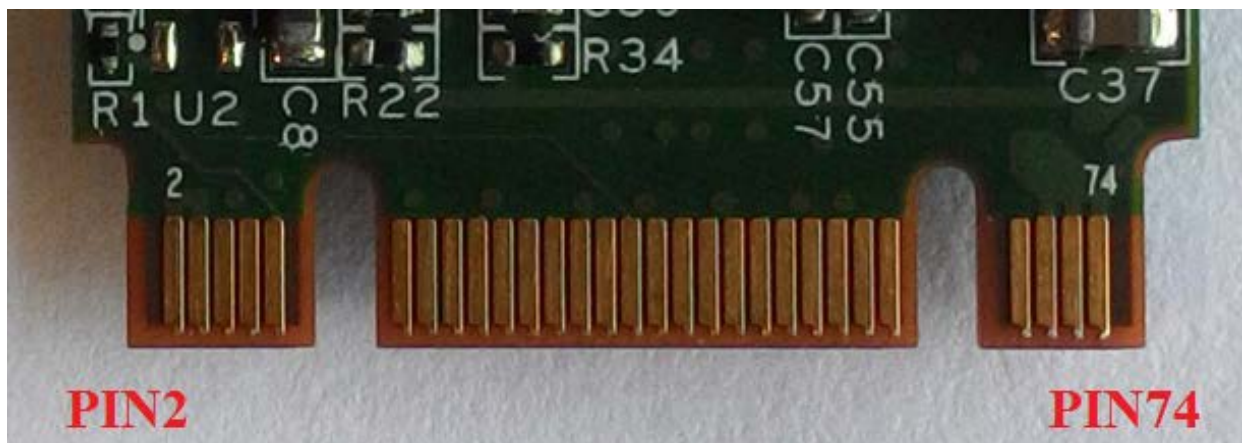

6.1.2 Pin Out Descriptions

Table 9: Pin Out Descriptions

Pin	Signal Name	Signal Description
10	DAS/DSS# (IO)	Device Activity Signal / Disable Staggered Spinup
38	DEVSLP (I)	Device Sleep Interface Power state
41	SATA - B+	Host Receive +
43	SATA - B-	Host Receive -
47	SATA - A-	Host Transmit -
49	SATA - A+	Host Transmit +
69	PEDET (GND-SATA)	Protocol detect signal: SATA (low) / PCIe (high)
5, 6, 7, 8, 11, 20, 22, 23, 24, 25, 26, 28, 29, 30, 31, 32, 34, 35, 36, 37, 40, 42, 44, 46, 48, 50, 52, 53, 54, 55, 56, 58, 67, 68	N/C	Not Configured
2, 4, 70, 72, 74	V3.3	3.3 V power
1, 3, 9, 21, 27, 33, 39, 45, 51, 57, 71, 73, 75	GND	Ground

6.2 Absolute Maximum Ratings

Table 10: Absolute Maximum Ratings

Symbol	Parameter	Minimum Value	Maximum Value	Unit
V _{CC3}	3.3 V Supply Voltage	-0.3	3.6	V
V _{IN3}	3.3 V Input Voltage	GND - 0.2	V _{CC} + 0.2	V
I _{IN3}	3.3 V DC Input Current	NA	750	mA
T _{STG}	Storage Temperature	-40	85	°C

6.3 Recommended Operating Conditions

Table 11: Recommended Operating Conditions

Parameter	Ratings
3.3 V Supply Voltage	3.3 V ± 5%
Operating Temperature - Commercial	0°C to 70°C
Operating Temperature - Industrial	-40°C to 85°C

7 ATA COMMANDS

This section documents the host interface commands the M.2 SATA drive supports.

7.1 Supported ATA Commands

The M.2 SATA drive supports the standard commands listed in the table below. For more detailed descriptions of the commands, please refer to the ATA-8 specification.

Table 12: Supported ATA Commands

Command Name	Op Code (Hex)	Command Set (Category)
NOP	00h	General
Data Set Management (Incl. TRIM)	06h	48-bit Address
Recalibrate	10h-1Fh	General
Read Sectors	20h	General
Read Sectors EXT	24h	48-bit Address
Read DMA EXT	25h	48-bit Address
Read Native Max Address EXT	27h	48-bit Address
Read Multiple EXT	29h	48-bit Address
Read Log EXT	2Fh	48-bit Address
Write Sectors	30h	General
Write Sectors EXT	34h	48-bit Address
Write DMA EXT	35h	48-bit Address
Set Native Max Address EXT	37h	48-bit Address
CFA WRITE SECTORS WITHOUT ERASE	38h	General
Write Multiple EXT	39h	48-bit Address
Write DMA FUA EXT	3Dh	48-bit Address
Write Long EXT	3Fh	48-bit Address
Read Verify Sectors	40h	General
Read Verify Sectors EXT	42h	48-bit Address
WRITE UNCORRECTABLE EXT	45h	48-bit Address
Read FPDMA Queued	60h	General
Write FPDMA Queued	61h	General
Seek	70h-7Fh	General
Execute Device Diagnostic	90h	General
Initialize Device Parameters	91h	General
Download Microcode	92h	General
STANDBY IMMEDIATE	94h	PwrMgmt
IDLE IMMEDIATE	95h	PwrMgmt
STANDBY	96h	PwrMgmt
IDLE	97h	PwrMgmt
CHECK POWER MODE	98h	PwrMgmt
SLEEP	99h	PwrMgmt
SMART	B0h	S.M.A.R.T.
DEVICE CONFIGURATION	B1h	DCO
Read Multiple	C4h	General
Write Multiple	C5h	General
Set Multiple Mode	C6h	General
Read DMA	C8h	General

Write DMA	CAh	General
Write Multiple FUA EXT	CEh	48-bit Address
Standby Immediate	E0h	PwrMgmt
Idle Immediate	E1h	PwrMgmt
Standby	E2h	PwrMgmt
Idle	E3h	PwrMgmt
Read Buffer	E4h	General
Check Power Mode	E5h	PwrMgmt
Sleep	E6h	PwrMgmt
Flush Cache	E7h	General
Write Buffer	E8h	General
Flush Cache EXT	EAh	48-bit Address
Identify Device	ECh	General
Set Features	EFh	General
Security Set Password	F1h	Security
Security Unlock	F2h	Security
Security Erase Prepare	F3h	Security
Security Erase Unit	F4h	Security
Security Freeze Lock	F5h	Security
Security Disable Password	F6h	Security
Read Native Max Address	F8h	HPA
Set Max Address	F9h	HPA

7.2 Supported S.M.A.R.T. Operations

Self-monitoring analysis and reporting technology (S.M.A.R.T.) commands provide diagnostic information regarding drive operation and, in certain cases, can assist in predicting drive degradation. Because S.M.A.R.T. alerts the host of possible drive problems, users can assess the situation and back up data prior to an operational failure.

Each S.M.A.R.T. attribute monitors a specific drive condition, with threshold levels configured for select attributes. When the drive exceeds these thresholds, the S.M.A.R.T. attribute reports the condition. In many cases, exceeding the threshold simply indicates you should monitor the drive more closely. Host systems initiate commands, generated manually or with a third-party diagnostic tool, to monitor S.M.A.R.T. attributes.

Although the M.2 SATA modules support several S.M.A.R.T. operations, which are subcommands of the S.M.A.R.T. Operations command (see Table 13), the S.M.A.R.T. Return Status and S.M.A.R.T. Read Data subcommands are used for monitoring the drive.

Initiating a S.M.A.R.T. Return Status command returns the current state of the drive, specifying whether or not an attribute exceeded the assigned threshold. If an attribute has exceeded a threshold level, SMART Modular Technologies recommends issuing the S.M.A.R.T. Read Data command to identify the specific attribute (see Table 15).

S.M.A.R.T. commands are issued with B0h in the Command register and the code for the desired operation in the Features register. A S.M.A.R.T. Enable Operations must be issued before any other S.M.A.R.T. command can be performed.

7.2.1 Supported S.M.A.R.T. Subcommands

Table 13: Supported S.M.A.R.T. Subcommands

Subcommand Name	Feature Code (Hex)
S.M.A.R.T. Read Data	D0
S.M.A.R.T. Read Attribute Thresholds	D1 (obsolete)
S.M.A.R.T. Enable/Disable Autosave	D2
S.M.A.R.T. Save Attribute Values	D3 (obsolete)
S.M.A.R.T. Execute Off-Line Immediate	D4
S.M.A.R.T. Enable Operations	D8
S.M.A.R.T. Disable Operations	D9
S.M.A.R.T. Return Status	DA

7.2.2 Supported S.M.A.R.T. Data Structure

Table 14: Supported S.M.A.R.T. Data Structure

Byte	Description
0 – 1	Revision code
2 – 361	Vendor-specific
362	Offline data collection status
363	Self-test execution status byte
364 – 365	Total time in seconds to complete offline data collection activity
366	Vendor-specific
367	Offline data collection capability
368 – 369	S.M.A.R.T. capability
370	Error logging capability 7-1 Reserved 0 1 = Device error logging supported
371	Vendor-specific
372	Short self-test routine recommended polling time (in minutes)
373	Extended self-test routine recommended polling time (in minutes)
374	Conveyance self-test routine recommended polling time (in minutes)
386 – 395	Firmware version/data code
396 – 397	Number of initial invalid block (396 = MSB, 397 = LSB)
400 – 406	SMART
407 – 415	Vendor-specific
417	Program/write the strong page only
418 – 419	Number of spare blocks
446 – 510	Vendor-specific
511	Data structure checksum

7.2.3 Supported S.M.A.R.T. Attributes

Table 15: Supported S.M.A.R.T. Attributes

Attribute Name	ID		Flags		Val	Min	Raw Attribute Value										
	Dec	Hex	1	2			3	4	5	6	7	8	9	10	11		
UECC Count	1	01h	0Bh	00h	64h	64h	Uncorrectable ECC Count		00h	00h	00h	00h	00h				
Reallocated Block Count	5	05h	13h	00h	64h	64h	Grown Bad Block Count		00h	00h	00h	00h	00h				
Power On Hours	9	09h	12h	00h	64h	64h	Power on Hours				00h	00h	00h				
Power Cycle Count	12	0Ch	12h	00h	64h	64h	Power on/off cycles				00h	00h	00h				
Device Capacity	14	0Eh	12h	00h	64h	64h	Device Capacity				00h	00h	00h				
User Capacity	16	0Fh	12h	00h	64h	64h	User Capacity				00h	00h	00h				
Initial Spare Blocks Available	17	10h	12h	00h	64h	64h	Spare Blocks Available		00h	00h	00h	00h	00h				
Spare Blocks Remaining*	18	11h	12h	00h	64h	64h	Remaining Spare Blocks		00h	00h	00h	00h	00h				
Total PE cycle Count (Drive)	100	64h	12h	00h	64h	64h	Total Erase Count					00h					
SATA PHY Error Count	168	A8h	12h	00h	64h	64h	SATA PHY Error Count			00h	00h	00h	00h				
Total Bad Block Count	170	AAh	03h	00h	64h	64h	Initial Bad Block		00h	00h	00h	00h	00h				
Total Block Erase Failures	172	ACh	12h	00h	64h	64h	Total Block Erase Failures		00h	00h	00h	00h	00h				
Max PE cycle Count (Block)	173	ADh	12h	00h	64h	64h	Max Erase Count		00h	00h	00h	00h	00h				
Unexpected Power Loss Count	174	A Eh	12h	00h	64h	64h	Surprise Power Removal Count				00h	00h	00h				
Average PE cycle Count (Block)	175	AFh	12h	00h	64h	64h	Average Erase Count				00h	00h	00h				
Total Block Program Failure	181	B5h	12h	00h	64h	64h	Program Fail Count		00h	00h	00h	00h	00h				
Background read UECC	187	BBh	12h	00h	64h	64h	UNC Error Count		00h	00h	00h	00h	00h				
Temperature	194	C2h	23h	00h	100 - Highest value	100 - Highest value	Current Temp		00h	00h	00h	00h	00h				
N/A	197	C5h	32h	00h	64h	64h	00h		00h	00h	00h	00h	00h				
N/A	198	C6h	12h	00h	64h	64h	00h		00h	00h	00h	00h	00h				
SATA FIS CRC Errors	199	C7h	0Bh	00h	64h	64h	CRC Error Count				00h	00h	00h				
% of Drive Life Used ⁽¹⁾	202	CAh	12h	00h	64h	64h	% Life Used		00h	00h	00h	00h	00h				
% of Drive Life Remaining ⁽¹⁾	231	E7h	13h	00h	64h	64h	% Life Remain		00h	00h	00h	00h	00h				
Read Failure Count	232	E8h	13h	00h	64h	64h	Read Failure Count		00h	00h	00h	00h	00h				
Total Flash Sectors Read	234	EAh	0Bh	00h	64h	64h	Lifetime Reads from Flash (Sector)						00h				
Total Flash Sectors Written	235	EBh	0Bh	00h	64h	64h	Lifetime Writes to Flash (Sector)						00h				

Attribute Name	ID	Flags	Val	Min	Raw Attribute Value	
Total Host Sectors Written	241	F1h 12h 00h	64h	64h	Lifetime Writes from Host (Sector)	00h
Total Host Sectors Read	242	F2h 12h 00h	64h	64h	Lifetime Reads from Host (Sector)	00h

(1) % Life Used = [(Max Erase Count / P/E Endurance Spec of NAND) x 100]

(2) % Life Remaining = 100 – [(Max Erase Count / P/E Endurance Spec of NAND) x 100]

7.3 Supported DCO Subcommands

Device Configuration Overlay (DCO) subcommands are issued with B1h in the Command register and the code for the desired command in the Feature register. See the following table for the supported subcommands and the corresponding Feature code.

Table 16: Supported DCO Subcommands

Subcommand Name	Code (Hex)
Device Configuration Freeze Lock	C1
Device Configuration Identify	C2
Device Configuration Restore	C0
Device Configuration Set	C3

7.4 Supported HPA Subcommands

Host Protected Area (HPA) subcommands are issued with F9h in the Command register and the code for the desired command in the Feature register. See the following table for the supported subcommands and the corresponding Feature code.

Table 17: Supported HPA Subcommands

Subcommand Name	Code (Hex)
Set Max Address	00
Set Max Freeze Lock	04
Set Max Lock	02
Set Max Set Password	01
Set Max Unlock	03

7.5 Identify Drive

This command passes to the Host one sector of data describing the Flash drive's parameters. The following table contains a detailed description of the Identify Drive data.

Table 18: Identify Device Information

Word	F: Fixed V: Variable X: Both	Default Value	Description
0	F	0040h	General configuration bit-significant information
1	X	*1	Obsolete – Number of logical cylinders
2	V	C837h	Specific configuration
3	X	0010h	Obsolete – Number of logical heads (16)
4 – 5	X	00000000h	Retired
6	X	003Fh	Obsolete – Number of logical sectors per logical track (63)
7 – 8	V	00000000h	Reserved for assignment by the Compact Flash Association
9	X	0000h	Retired
10 – 19	F	Varies	Serial number (20 ASCII characters)
20 – 21	X	0000h	Retired
22	X	0000h	Obsolete
23 – 26	F	Varies	Firmware revision (8 ASCII characters)
27 – 46	F	Varies	Model number (xxxxxxx)
47	F	8010h	7:0- Maximum number of sectors transferred per interrupt on MULTIPLE commands
48	F	4000h	Trusted Computing feature set options(not support)
49	F	2F00h	Capabilities
50	F	4000h	Capabilities
51 – 52	X	00000000h	Obsolete
53	F	0007h	Words 88 and 70:64 valid
54	X	*1	Obsolete – Number of logical cylinders
55	X	0010h	Obsolete – Number of logical heads (16)
56	X	003Fh	Obsolete – Number of logical sectors per track (63)
57 – 58	X	*2	Obsolete – Current capacity in sectors
59	F	0110h	Number of sectors transferred per interrupt on MULTIPLE commands
60-61	F	*3	Maximum number of sector (28-bit LBA mode)
62	X	0000h	Obsolete
63	F	0407h	Multi-word DMA modes supported/selected
64	F	0003h	PIO modes supported
65	F	0078h	Minimum Multiword DMA transfer cycle time per word

Word	F: Fixed V: Variable X: Both	Default Value	Description
66	F	0078h	Manufacturer's recommended Multiword DMA transfer cycle time
67	F	0078h	Minimum PIO transfer cycle time without flow control
68	F	0078h	Minimum PIO transfer cycle time with IORDY flow control
69	F	0100h	Additional Supported (support download microcode DMA)
70	F	0000h	Reserved
71 – 74	F	0000000000000000h	Reserved for the IDENTIFY PACKET DEVICE command
75	F	001Fh	Queue depth
76	F	670eh	Serial SATA capabilities
77	F	0084h	Serial ATA Additional Capabilities
78	F	014Ch	Serial ATA features supported
79	V	0040h	Serial ATA features enabled
80	F	07F8h	Major Version Number
81	F	0000h	Minor Version Number
82	F	346bh	Command set supported
83	F	7d09h	Command set supported
84	F	6063h	Command set/feature supported extension
85	V	3469h	Command set/feature enabled
86	V	bc01h	Command set/feature enabled
87	V	6063h	Command set/feature default
88	V	003Fh	Ultra DMA Modes
89	F	0001h	Time required for security erase unit completion
90	F	001Eh	Time required for Enhanced security erase completion
91	V	0000h	Current advanced power management value
92	V	FFFEh	Master Password Revision Code
93	F	0000h	Hardware reset result. The contents of the bits (12:0) of this word can be changed only during the execution of hardware reset.
94	V	0000h	Vendor's recommended and actual acoustic management value
95	F	0000h	Stream Minimum Request Size
96	V	0000h	Streaming Transfer Time – DMA
97	V	0000h	Streaming Access Latency – DMA and PIO
98 – 99	F	0000h	Streaming Performance Granularity
100 – 103	V	*4	Maximum user LBA for 48-bit Address feature set
104	V	0000h	Streaming Transfer Time – PIO
105	F	0008h	Maximum number of 512-byte blocks per DATA SET

Word	F: Fixed V: Variable X: Both	Default Value	Description
			MANAGEMENT command
106	F	4000h	Physical sector size/Logical sector size
107	F	0000h	Inter-seek delay for ISO-7779 acoustic testing in microseconds
108 – 111	F	0000000000000000h	Unique ID
112 – 115	F	0000000000000000h	Reserved
116	V	0000h	Reserved
117 – 118	F	00000000h	Words per logical Sector
119	F	4014h	Supported settings
120	F	4014h	Command set/Feature Enabled/Supported
121 – 126	F	0h	Reserved
127	F	0h	Removable Media Status Notification feature set support
128	V	0021h	Security status
129 – 140	X	0h	Vendor specific
141	X	0001h	Vendor specific
142 – 159	X	0h	Vendor specific
160	F	0h	Compact Flash Association (CFA) power mode 1
161 – 167	X	0h	Reserved for assignment by the CFA
168	F	3h 2.5 inch 4h 1.8 inch 5h less than 1.8 inch	Device Nominal Form Factor
169	F	0001h	DATA SET MANAGEMENT command is supported
170 – 173	F	0h	Additional Product Identifier
174 – 175		0h	Reserve
176 – 205	V	0h	Current media serial number
206	F	0h	SCT Command Transport
207 – 208	F	0h	Reserved
209	F	4000h	Alignment of logical blocks within a physical block
210 – 211	V	0000h	Write-Read-Verify Sector Count Mode 3 (not support)
212 – 213	F	0000h	Write-Read-Verify Sector Count Mode 2 (not support)
214 – 216		0000h	NV Cache relate (not support)
217	F	0001h	Non-rotating media device
218	F	0h	Reserved
219	F	0h	NV Cache relate (not support)
220	V	0h	Write read verify feature set current mode
221		0h	Reserved

Word	F: Fixed V: Variable X: Both	Default Value	Description
222	F	107Fh	Transport major version number
223	F	0h	Transport minor version number
224 – 229		0h	Reserved
230 – 233		0h	Extend number of user addressable sectors
234		0001h	Minimum number of 512-byte data blocks per DOWNLOAD MICROCODE command for mode 03h
235		0080h	Maximum number of 512-byte data blocks per DOWNLOAD MICROCODE command for mode 03h
236 – 254	F	0h	Reserved
255	X	XXA5h XX is variable	Integrity word (Checksum and Signature)

Table 19: Device Identification by Capacity

Capacity (GB)	*1 (Word 1/Word 54)	*2 (Word 57 - 58)	*3 (Word 60 - 61)	*4 (Word 100 - 103)
8	3CA5h	EEC9B0h	EEC9B0h	EEC9B0h
16	3FFFh	FBFC10h	1DD40B0h	1DD40B0h
32	3FFFh	FBFC10h	3BA2EB0h	3BA2EB0h
64	3FFFh	FBFC10h	7740AB0h	7740AB0h

8 PART NUMBERS

8.1 Part Numbering Information

Table 20: Part Numbering Information

SMART Part Number	Capacity	Addressable LBAs	Unformatted Capacity
SH9M2S46D008GJS01	8 GB	15,649,200	8,012,390,400 Bytes
SH9M2S46D008GJSI01	8 GB	15,649,200	8,012,390,400 Bytes
SH9M2S46D016GJS01	16 GB	31,277,232	16,013,942,784 Bytes
SH9M2S46D016GJSI01	16 GB	31,277,232	16,013,942,784 Bytes
SH9M2S46D032GJS01	32 GB	62,533,296	32,017,047,552 Bytes
SH9M2S46D032GJSI01	32 GB	62,533,296	32,017,047,552 Bytes
SH9M2S46D064GJS01	64 GB ⁽¹⁾	125,045,424	64,023,257,088 Bytes

(1) 64 GB available in Commercial temperature grade only

8.2 Part Number Decoder

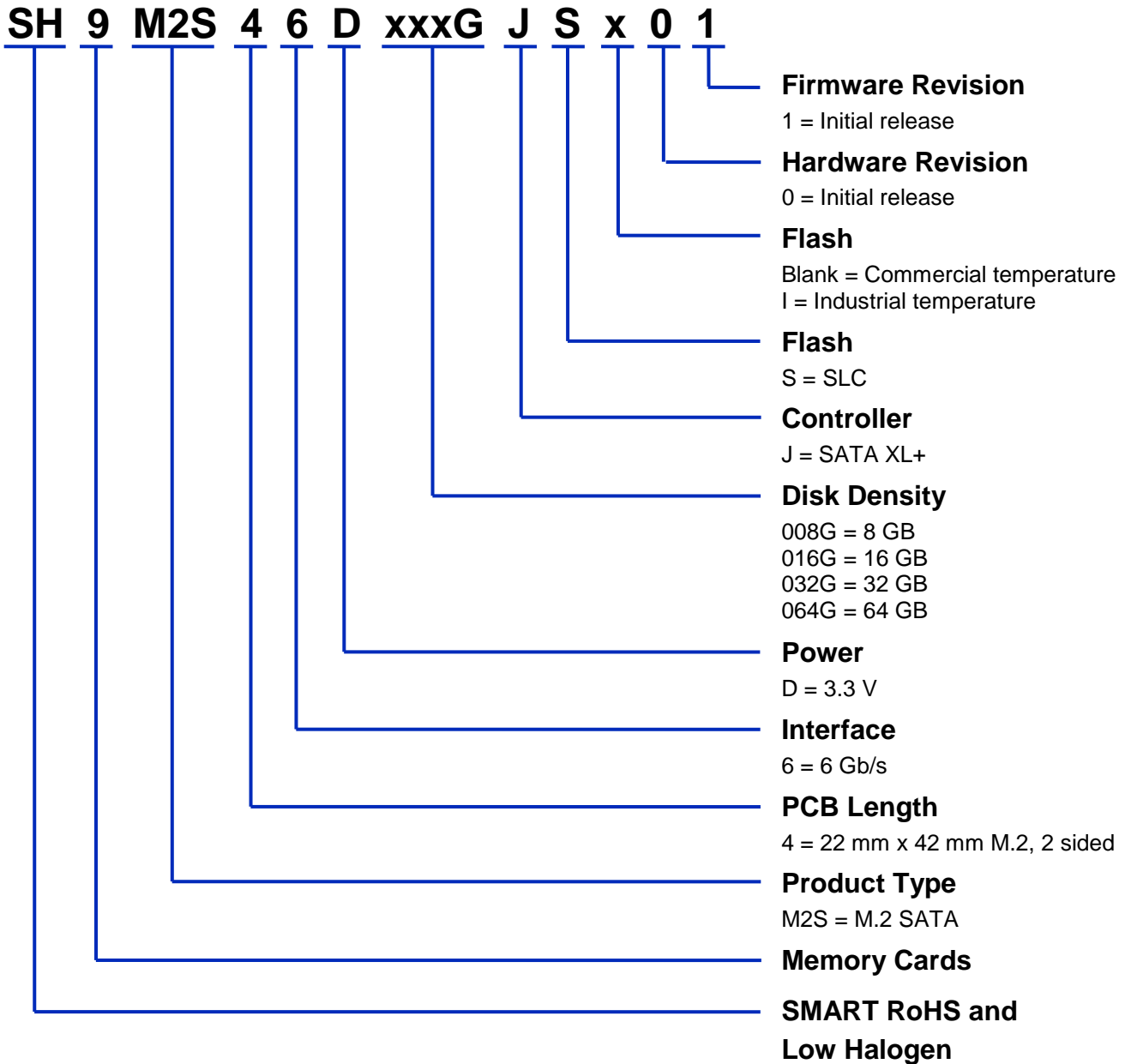

Declaration of Conformity

Responsible Party Name: SMART Modular Technologies, Inc.
Address: 39870 Eureka Drive
Newark, CA 94560-4809, USA
Phone: +1-510-623-1231

hereby declares that the products:

SH9M2S46DxxxGJSxxx

to which this declaration relates are in conformity with the following Directives and other normative documents:

RoHS Directive 2011/65/EU

Restriction of the use of certain hazardous substances in electrical and electronic equipment

- **EN 50581:2012**
Technical documentation for the assessment of electrical and electronic products with respect to the restriction of hazardous substances

Name: Jeffrey Milano
Title: Director, Worldwide Quality
Date: January 16, 2015 9:53 AM

Representative in the European Union (for regulatory topics only):

Mr. Graham Kyle
SMART Modular Technologies (Europe) Ltd.
312 Nasmyth Building, Nasmyth Avenue
Scottish Enterprise Technology Park
East Kilbride, Scotland, G75 0QR

Disclaimer:

No part of this document may be copied or reproduced in any form or by any means, or transferred to any third party, without the prior written consent of an authorized representative of SMART Modular Technologies, Inc. ("SMART"). The information in this document is subject to change without notice. SMART assumes no responsibility for any errors or omissions that may appear in this document, and disclaims responsibility for any consequences resulting from the use of the information set forth herein. SMART makes no commitments to update or to keep current information contained in this document. The products listed in this document are not suitable for use in applications such as, but not limited to, aircraft control systems, aerospace equipment, submarine cables, nuclear reactor control systems, and life support systems. Moreover, SMART does not recommend or approve the use of any of its products in life support devices or systems, or in any application where failure could result in injury or death. If a customer wishes to use SMART products in applications not intended by SMART, said customer must contact an authorized SMART representative to determine SMART's willingness to support a given application. The information set forth in this document does not convey any license under the copyrights, patent rights, trademarks, or other intellectual property rights claimed and owned by SMART. The information set forth in this document is considered to be "Proprietary" and "Confidential" property owned by SMART.

ALL PRODUCTS SOLD BY SMART ARE COVERED BY THE PROVISIONS APPEARING IN SMART'S TERMS AND CONDITIONS OF SALE ONLY, INCLUDING THE LIMITATIONS OF LIABILITY, WARRANTY, AND INFRINGEMENT PROVISIONS. SMART MAKES NO WARRANTIES OF ANY KIND, EXPRESS, STATUTORY, IMPLIED, OR OTHERWISE, REGARDING INFORMATION SET FORTH HEREIN OR REGARDING THE FREEDOM OF THE DESCRIBED PRODUCTS FROM INTELLECTUAL PROPERTY INFRINGEMENT, AND EXPRESSLY DISCLAIMS ANY SUCH WARRANTIES INCLUDING WITHOUT LIMITATION ANY EXPRESS, STATUTORY, OR IMPLIED WARRANTIES OF MERCHANTABILITY OR FITNESS FOR A PARTICULAR PURPOSE.

©1/16/15 SMART Modular Technologies, Inc. All rights reserved.